

HD POWER TRANSDUCER SERIES

VOLT-DEMAND TRANSDUCER

MODEL HDH -

MODEL & SUFFIX CODE SELECTION

MODEL **HDH** — [] [] []

■ **INPUT**

1	AC 0 – 150V
2	AC 0 – 300V
3	AC 0 – 500V
0	Spec Order

■ **OUTPUT**

A	DC 4-20mA	1	DC 0-10mV
B	DC 0-1mA	2	DC 0-100mV
C	DC 0-20mA	3	DC 0-1V
D	DC 0-10mA	4	DC 0-10V
E	DC 1-5mA	5	DC 0-5V
0	Spec Order	6	DC 1-5V
		0	Spec Order

■ **MODE**

A	Average
R	R.M.S

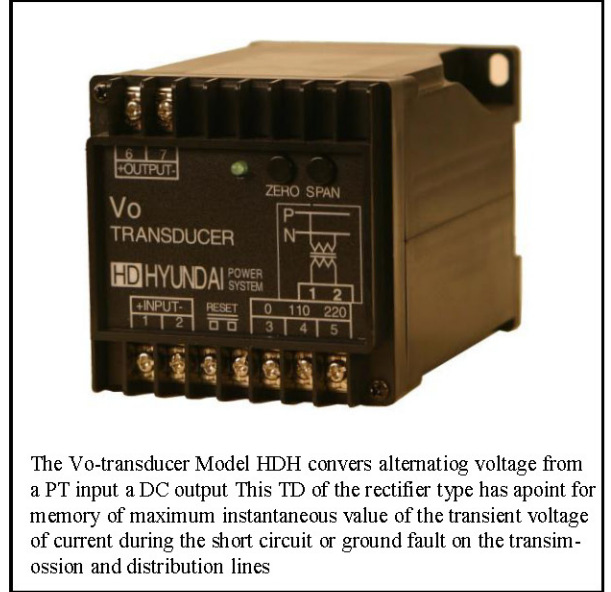

The Vo-transducer Model HDH converts alternating voltage from a PT input a DC output This TD of the rectifier type has a point for memory of maximum instantaneous value of the transient voltage of current during the short circuit or ground fault on the transmission and distribution lines

ORDERING INFORMATION

Specify code number and variables
 * **Code number** : HDH-input/output/mode
 ex : HDH-2AR
 * **special output range** :
 A = -10~20mA
 V = -10~12V

GENERAL SPECIFICATIONS

Construction : DIN housings Terminal access on front face
Housing material : plastic(black)
Wiring : 3.0M screw terminals
Isolation : AC input/DC output/power
Adjustments : zero and span $\pm 5\%$
 Over-range output = 0-120%

PERFORMANCE

Accuracy : 0.1% or 0.25%
Temp.coefficient : 0.03%/C
Insulation resistance : 100Mohm or more with 500V DC
Response time : 0.4sec(400ms)
Line Voltage effect : 0.1% with 10% change
Ripple : 0.25% p-p max. (100/120Hz)
Dielectric strength : 2000V AC 1minute
 input/output/power
Surge withstand Voltage : 1.2/50 μ sec, $\pm 5KV$
 (INPUT to OUTPUT to GROUND)

INSTALLATION

Operating temperature : -5 to +55C
Operating humidity : 20-80%RH(non-condensing)
Mounting : Wall or DIN rail
Power supply : AC 110V or 220V (-15/+10%)
 50/60Hz,2VA
Size : W75 H75 D113mm
Weight :

INPUT & OUTPUT

■ **INPUT**
input : AC 0-150V or AC 0-300V or AC 0-500V
Operational range : 0-120%
Permissible over range : 1000% for 5 seconds
 200% for 20 seconds
 120% continuously
Frequency : 50/60Hz
Input loss : 0.5VA or less

■ OUTPUT

DC Current : 0-20mA DC

Minimum span : 1mA

zero bias : max. 1.5 Times of span

LOAD resistance

OUTPUT	LOAD RESISTANCE	IMPEDANCE
4-20mA	0-600 Ω	5Mohm or more
0-20mA	0-600 Ω	
0-16mA	0-750 Ω	
0-10mA	0-1200 Ω	
0-1mA	0-12 kΩ	
0-5mA	0-2400 Ω	

DC Voltage : 0-12V DC

Minimum span : 5mV

zero bias : max. 1.5 Times of span

OUTPUT	LOAD RESISTANCE	IMPEDANCE
0-10mV	10 kΩ or more	10 Ω
0-100mV	100 kΩ or more	100 Ω
0-1V	1 kΩ or more	1 Ω or less
0-10V	10 kΩ or more	
0-5V	5 kΩ or more	
1-5V		

* for other ranges within 0-12V, use equation
 $R = E/I$ where : R = load resistance (Ω)
 E = full-scale output (V)
 I = 1 mA

CONNECTION DIAGRAM

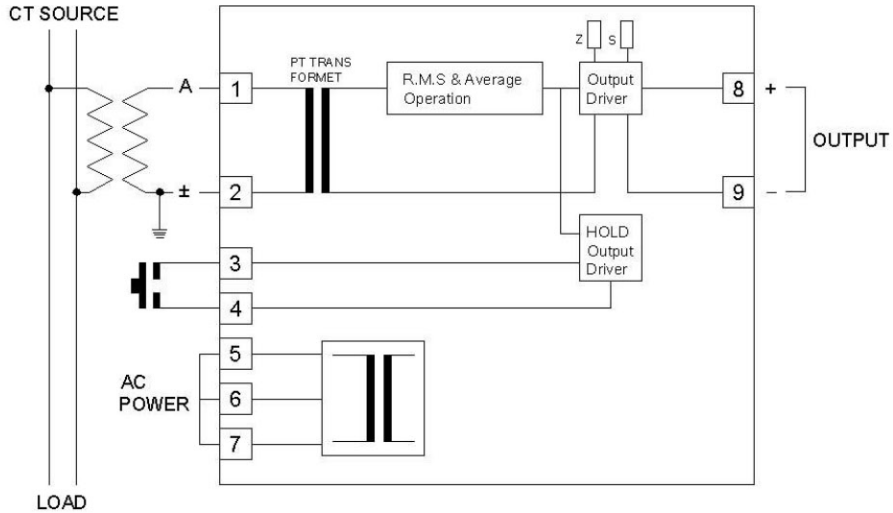

DIMENSION & INSTRUCTIONS

