

HD POWER TRANSDUCER SERIES
DC TRANSDUCER

MODEL

HDD -
MODEL & SUFFIX CODE SELECTION

 MODEL **HDD** —
INPUT

1	0 - 50mV
2	0 - 100mV
3	0 - 1V
4	0 - 10V
5	0 - 150V
6	0 - 300V
7	1 - 5V
A	4 - 20mA
B	0 - 1mA
C	0 - 20mA
D	0 - 10mA
O	Spec Order

OUTPUT

A	DC 4-20mA
B	DC 0-1mA
C	DC 0-10mA
D	DC 0-20mA
E	DC 1-5mA
O	Spec Order

1	DC 0-10mV
2	DC 0-100mV
3	DC 0-1V
4	DC 0-10V
5	DC 0-5V
6	DC 1-5V
O	Spec Order



The DC Isolated Converter Model HDD is an isolated signal transmitter featuring fast response time 0.4 seconds
* isolated mode : photocoupler

ORDERING INFORMATION

Specify code number and variables

 * **Code number** : HDD-input/output/mode
 ex : HDD-1A

Output2 : Availability as output1 : None

 * **special output range** :

 A = -10~20mA
 V = -10~12V

GENERAL SPECIFICATIONS
Construction : DIN housings Terminal access on front face

Housing material : plastic(black)

Wiring : 3.0M screw terminals

Isolation : AC input/DC output/power

Adjustments : zero and span $\pm 5\%$

Over-range output = 0-120%

PERFORMANCE
Accuracy : 0.1% or 0.25%

Temp.coefficient : 0.03%/C

Insulation resistance : 100Mohm or more with 500V DC

Response time : 0.4sec(400ms)

Line Voltage effect : 0.1% with 10% change

Ripple : 0.25% p-p max. (100/120Hz)

Dielectric strength : 2000V AC 1minute

input/output/power

Surge withstand Voltage : 1.2/50 μ sec. $\pm 5KV$

(INPUT to OUTPUT to GROUND)

INSTALLATION
Operating temperature : -5 to +55C

Operating humidity : 20-80%RH(non-condensing)

Mounting : Wall or DIN rail

Power supply : AC 110V or 220V (-15/+10%)
 50/60Hz,2VA

Size : W75 H75 D113mm

Weight :

INPUT & OUTPUT

 • **DC Current** : shunt resistor attached to input terminals (0.5W)

Input resistance : For resistance values other than listed below, specify when ordering.

Input	Input Resistance
4 - 20mA	: 250 (Ω) (100 Ω for orders)
2 - 10mA	: 500
1 - 5mA	: 1000
0 - 20mA	: 50
0 - 16mA	: 62.5
0 - 10mA	: 100
0 - 1mA	: 1000
10 - 50mA	: 100
0 - 10 μ A	: 1000
0 - 100 μ A	: 1000
-1 - +1mA	: 1000
-10 - +10mA	: 100

■ **OUTPUT**

DC Current : 0-20mA DC

Minimum span : 1mA

zero bias : max. 1.5 Times of span

LOAD resistance

OUTPUT	LOAD RESISTANCE	IMPEDANCE
4-20mA	0-600 Ω	5M Ω or more
0-20mA	0-600 Ω	
0-16mA	0-750 Ω	
0-10mA	0-1200 Ω	
0-1mA	0-12 kΩ	
0-5mA	0-2400 Ω	

DC Voltage : 0-12V DC

Minimum span : 5mV

zero bias : max. 1.5 t Times of span

OUTPUT	LOAD RESISTANCE	IMPEDANCE
0-10mV	10 kΩ or more	10 Ω
0-100mV	100 kΩ or more	100 Ω
0-1V	1 kΩ or more	1Ω or less
0-10V	10 kΩ or more	
0-5V	5 kΩ or more	
1-5V		

* for other ranges within 0-12V, use equation
 $R = E/I$ where : R = load resistance (Ω)
 E = full-scale output (V)
 I = 1 mA

CONNECTION DIAGRAM

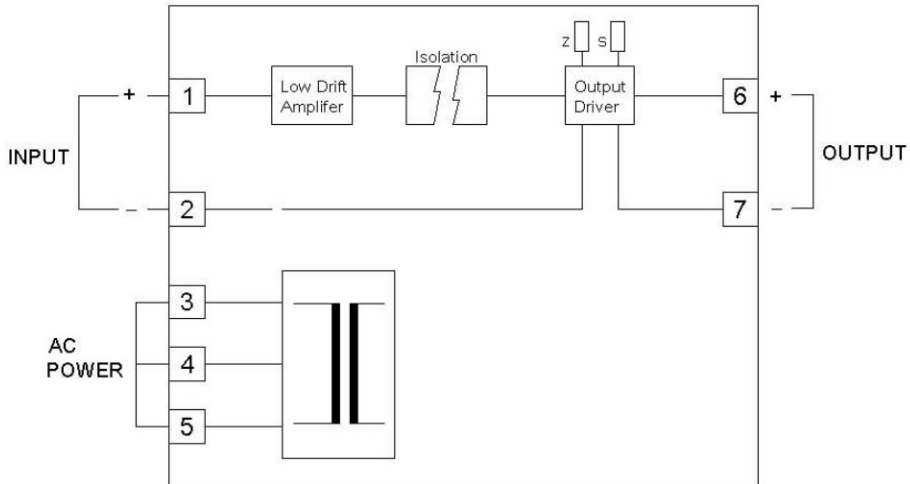

DIMENSION & INSTRUCTIONS

