

HD POWER TRANSDUCER SERIES

3 PHASE **AMPERE TRANSDUCER**

MODEL **HD3A -**

MODEL & SUFFIX CODE SELECTION

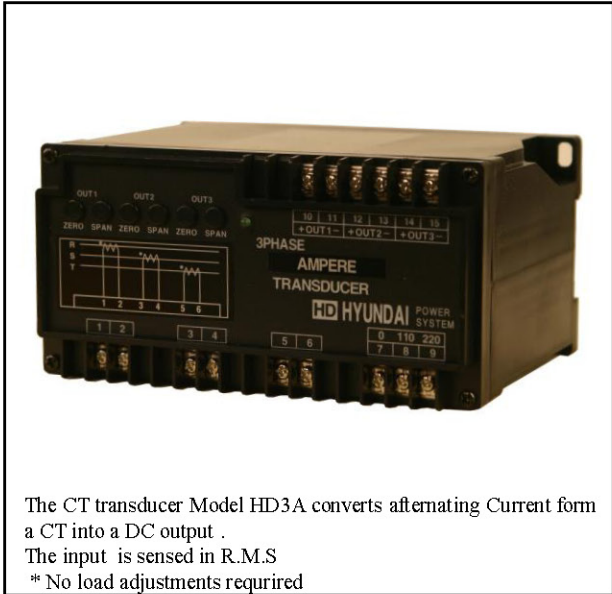
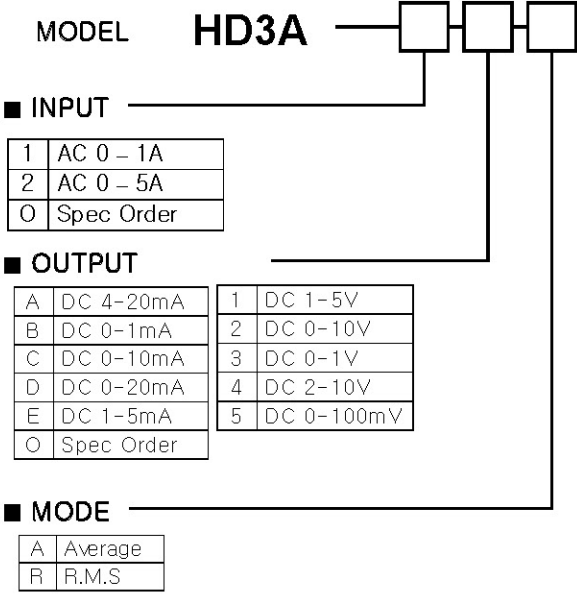

The CT transducer Model HD3A converts alternating Current form a CT into a DC output .
The input is sensed in R.M.S
* No load adjustments required

ORDERING INFORMATION

Specify code number and variables
 * **Code number** : HD3A-input/output/mode
 ex : HD3A-2AR
 * **special output range** :
 A = -10~20mA
 V = -10~12V

GENERAL SPECIFICATIONS

Construction : DIN housings Terminal access on front face
Housing material : plastic(black)
Wiring : 3.0M screw terminals
Isolation : AC input/DC output/power
Adjustments : zero and span $\pm 5\%$
 Over-range output = 0-120%

PERFORMANCE

Accuracy : 0.1% or 0.25%
Temp.coefficient : 0.03%/C
Insulation resistance : 100M Ω or more with 500V DC
Response time : 0.4sec(400ms)
Line Voltage effect : 0.1% with 10% change
Ripple : 0.25% p-p max. (100/120Hz)
Dielectric strength : 2000V AC 1minute
 input/output/power
Surge withstand Voltage : 1.2/50 μ sec, $\pm 5KV$
 (INPUT to OUTPUT to GROUND)

INSTALLATION

Operating temperature : -5 to +55C
Operating humidity : 20-80%RH(non-condensing)
Mounting : Wall or DIN rail
Power supply : AC 110V or 220V (-15/+10%)
 50/60Hz,2VA (DC 24V)
Size : W75 H150 D113mm
Weight :

INPUT & OUTPUT

■ **INPUT**
input : 0-1A AC or 0-5A AC 3PHASE 3CT
Operational range : 0-120%
Permissible over range : 100% for 5 seconds
 200% for 20 seconds
 120% continuously
Frequency : 50/60Hz
Input loss : 0.5VA or less

■ **OUTPUT**

DC Current : 0-20mA DC

Minimum span : 1mA

zero bias : max. 1.5 Times of span

LOAD resistance

OUTPUT	LOAD RESISTANCE	IMPEDANCE
4-20mA	0-600 Ω	5 MΩ or more
0-20mA	0-600 Ω	
0-16mA	0-750 Ω	
0-10mA	0-1200 Ω	
0-1mA	0-12 kΩ	
0-5mA	0-2400 Ω	

DC Voltage : 0-12V DC

Minimum span : 5mV

zero bias : max. 1.5 Times of span

LOAD resistance

OUTPUT	LOAD RESISTANCE	IMPEDANCE
0-10mV	10 kΩ or more	10 Ω
0-100mV	100 kΩ or more	100 Ω
0-1V	1 kΩ or more	1 Ω or less
0-10V	10 kΩ or more	
0-5V	5 kΩ or more	
1-5V		

* for other ranges within 0-12V, use equation
 $R = E/I$ where : R = load resistance (Ω)
 E = full-scale output (V)
 I = 1 mA

CONNECTION DIAGRAM

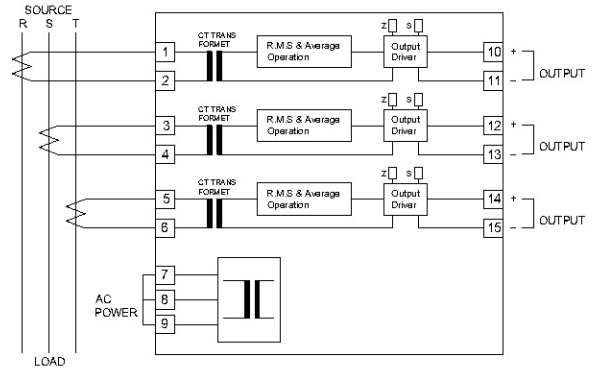

DIMENSION & INSTRUCTIONS

