

HD POWER TRANSDUCER SERIES

AC VOLTAGE TRANSDUCER

MODEL
HDV - HD1V -

모델명 및 표시방법

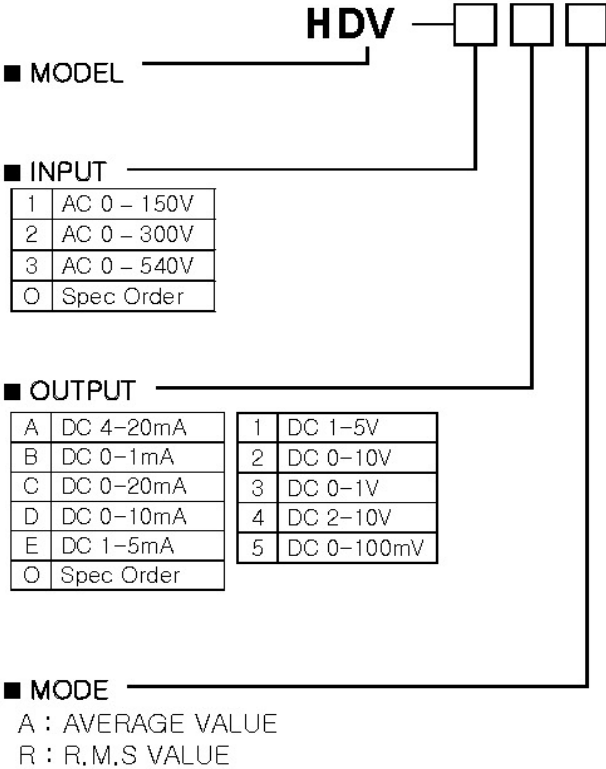

일반 사양

- 보조 전원 (Auxiliary power supply)
: AC 110V or 220V (-15%/10%)50/60Hz.0.5VA
- 오차 (Accuracy) : $\pm 0.25\%$ FS
- 응답속도 (Response Time) : 0.4sec(400ms)
- 리플 (Ripple) : 0.25% p_p Max(100/120Hz)
- 온도 영향 (Temp' Coefficient) : 0.015%/ $^{\circ}$ C
- 출력 허용 범위 (Overrange Output) : -10 ~ 120%
- 조정 범위 (Front Adjustments) : Zero : 5% 이내
Span : 15% 이내
- 사용 온도 (Operating temp') : 0 ~ +55 $^{\circ}$ C
- 사용 습도 (Operating humidity) : 20 - 80% RH
(non condensing)
- 내전압 (Dielectric strength) : AC 2000V /1Min
(외부 단자와 케이스 간)
- 절연 저항 (Insulation resistance) : 100M Ω
or more with DC 500V
- 충격 전압 (Surge withstand voltage)
: 1.2/50usec, ± 5 KV
- 내충격 : 30G, 3축방향 각3회(JISCO912)
- 부하저항 : 600 Ω
- 크기 : W75 x H75 x D113 (W75 x H150 x D113)
- 중량 :

입출력 동작사양

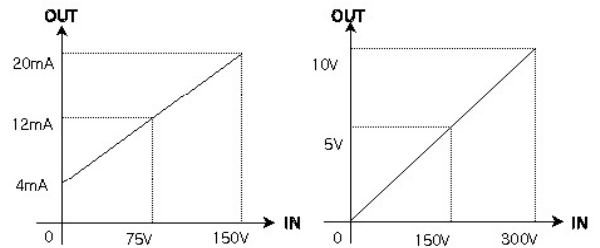

결선 방법

